

B60E

ARTICULATED DUMP TRUCK

4x4



Stage IV/Tier 4f Certified

- Gross Power: 430 kW (577 hp)
- Heaped Capacity: 35 m³ (45.8 yd³)
- Rated Payload: 55 000 kg (121 254 lbs)
- Operating Weight: 97 476 kg (214 898 lb)

BELL

Technical Data - B60E

ENGINE

Manufacturer
Mercedes Benz (MTU)

Model
OM473LA (MTU 6R 1500)

Configuration
Inline 6, turbocharged and intercooled.

Gross Power
430 kW (577 hp) @ 1 700 rpm

Net Power
405 kW (543 hp) @ 1 700 rpm

Gross Torque
2 750 Nm (2 028 lbf) @ 1 300 rpm

Displacement
15,6 litres (952 cu.in)

Auxiliary Brake
Engine Valve Brake

Fuel Tank Capacity
395 litres (104 US gal)

AdBlue® Tank Capacity
40 litres (11 US gal)

Certification
OM473LA (MTU 6R 1500) meets EU Stage 4 / EPA Tier 4 Final emissions regulations.

TRANSMISSION

Manufacturer
Allison

Model
4800 ORS

Configuration
Fully automatic planetary transmission

Layout
Engine mounted

Gear Layout
Constant meshing planetary gears, clutch operated

Gears
7 Forward, 1 Reverse

Clutch Type
Hydraulically operated multi-disc

Control Type
Electronic

Torque Control
Hydrodynamic with lock-up in all gears.

TRANSFER CASE

Manufacturer
Kessler

Model
W3430

Layout
Remote mounted

Gear Layout
Three in-line helical gears

Output Differential
Interaxle 33/67 proportional differential. Automatic inter-axle differential lock.

AXLES

Manufacturer
Front - Bell
Rear - Kessler

Model
Front: 30T
Rear: 71T

Differential
Front: High input controlled traction differential with spiral bevel gears

Rear: Centre input open differential with spiral bevel gears

Final Drive
Outboard heavy duty planetary on all axles.

BRAKING SYSTEM

Service Brake
Dual circuit, full hydraulic actuation wet disc brakes on front and rear axles. Wet brake oil is circulated through a filtration and cooling system.

Maximum brake force:
437 kN (98 242 lbf)

Park & Emergency
Spring applied, air released driveline mounted disc.

Maximum brake force:
379 kN (85 203 lbf)

Auxiliary Brake
Automatic engine valve brake. Automatic retardation through electronic activation of wet brake system.

Total Retardation Power
Continuous: 574 kW (770 hp)
Maximum: 983 kW (1 318 hp)

WHEELS

Type
Radial Earthmover

Tyre
Front: 875/65 R29
Rear: Twin 24.00 R35

FRONT SUSPENSION

Semi-independent, leading A-frame supported by hydro-pneumatic suspension struts. Suspension is electronically controlled adaptive suspension with ride height adjustment.

REAR SUSPENSION

Trailing arm cradle supported by hydro-pneumatic suspension struts, with an additional lateral stabiliser.

HYDRAULIC SYSTEM

Full load sensing system serving the prioritized steering, body tipping, suspension and brake functions. A ground-driven, load sensing emergency steering pump is integrated into the main system.

Pump Type
Variable displacement load sensing piston

Flow
330 L/min (87 gal/min)

Pressure
250 bar (3 626 psi)

Filter
5 microns

STEERING SYSTEM

Double acting cylinders, with ground-driven emergency steering pump.

Lock to lock turns
4,9

Steering Angle
42°

DUMPING SYSTEM

Two double-acting, two stage telescopic, dump cylinders.

Raise Time
13,5 seconds

Lowering Time
13,5 seconds

Tipping Angle
55 deg standard, or any lower angle programmable

PNEUMATIC SYSTEM

Air drier with heater and integral unloader valve, serving park brake and auxiliary functions.

System Pressure
810 kPa (117 psi)

ELECTRICAL SYSTEM

Voltage
24 V

Battery Type
Two AGM (Absorption Glass Mat) type.

Battery Capacity
2 X 75 Ah

Alternator Rating
28V 80A

MAX. VEHICLE SPEED

	km/h	mph
1st	4	2,5
2nd	8	5,6
3rd	16	10,6
4th	21	13,7
5th	30	20
6th	41	27
7th	47	32
R	6	4

CAB

ROPS/FOPS certified 74 dBA internal sound level measured according to ISO 6396.

Load Capacity & Ground Pressure

OPERATING WEIGHTS		GROUND PRESSURE*		LOAD CAPACITY		OPTION WEIGHTS	
UNLADEN	kg (lb)	LADEN		BODY	m ³ (yd ³)	kg (lb)	
Front	20 211 (44 558)	(No sinkage/Total Contact Area Method)		Struck Capacity	27 (35.3)	Bin liner	1 116 (2 460)
Rear	22 265 (49 086)	875/65 R29	kPa (Psi)	SAE 2:1 Capacity	35 (45.8)		
Total	42 476 (93 644)	Front	333 (48)	SAE 1:1 Capacity	42 (54.9)		
		24.00 R35	kPa	Rated Payload	55 000 kg	EXTRA WHEELSET	
Front	26 811 (59 108)	Rear	469 (68)		(121 254 lb)	875/65 R29	1 024 (2 258)
Rear	70 665 (155 768)					24.00 R34	1 240 (2 734)
Total	97 476 (214 898)						

* Front ground pressure calculated with Michelin XAD65-1 tyre. Rear ground pressure calculated with Michelin XDT B tyre.

Dimensions

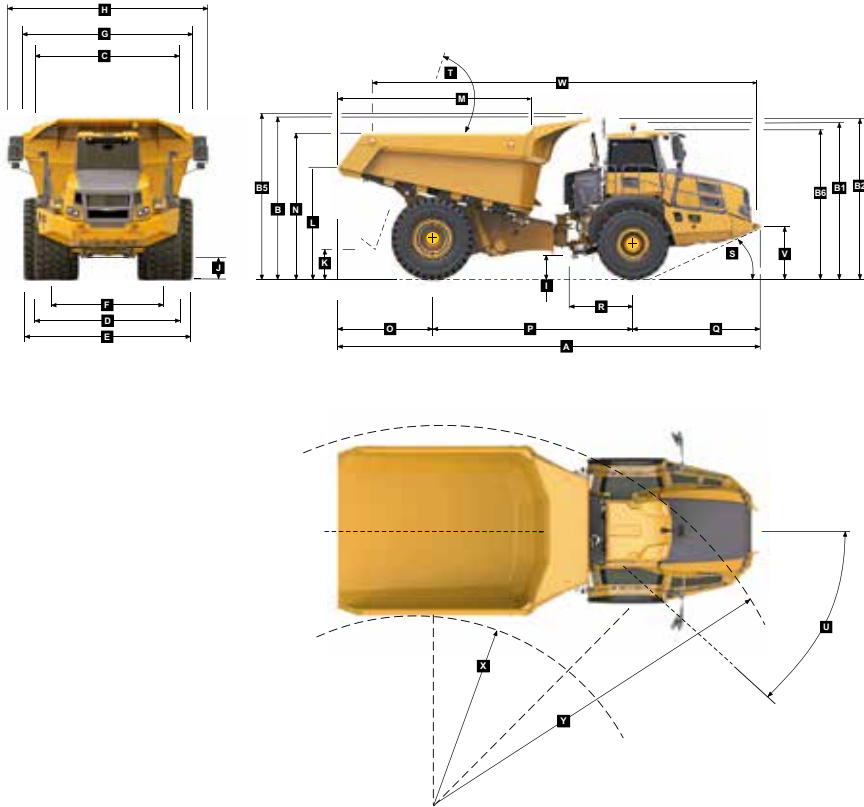

Machine Dimensions

A	Length - Transport Position	11114 mm (36 ft. 6 in.)
B	Height - Transport Position w/o Rock Guard	4209 mm (13 ft. 10 in.)
B	Height - Transport Position with Rock Guard	4212 mm (13 ft. 10 in.)
B1	Height - Rotating Beacon	4050 mm (13 ft. 3 in.)
B2	Height - Load Light	4333 mm (14 ft. 2 in.)
B5	Height - Rock Guard Operating Position	4675 mm (15 ft. 4 in.)
B6	Height - Cab	3813 mm (12 ft. 6 in.)
C	Width over Mudguards	3790 mm (12 ft. 5 in.)
D	Width over Tyres - Front - 875/65 R29	3832 mm (12 ft. 7 in.)
E	Width over Tyres - Rear - 24.00R35	4444 mm (14 ft. 7 in.)
F	Tyre Track Width - Front	2949 mm (9 ft. 8 in.)
F	Tyre Track Width - Rear	2992 mm (9 ft. 10 in.)
G	Width over Bin	4487 mm (14 ft. 9 in.)
H	Width over Mirrors - Operating Position	5242 mm (17 ft. 2 in.)
I	Ground Clearance - Artic	561 mm (22.09 in.)
J	Ground Clearance - Front Axle	554 mm (21.81 in.)
K	Ground Clearance - Bin Fully Tipped	851 mm (33.5 in.)
L	Bin Lip Height - Transport Position	2952 mm (9 ft. 8 in.)
M	Bin Length	5036 mm (16 ft. 6 in.)
N	Load over Height	3824 mm (12 ft. 7 in.)
O	Rear Axle Centre to Bin Rear	2477 mm (8 ft. 2 in.)
P	Rear Axle Centre to Front Axle Centre	5285 mm (17 ft. 4 in.)
Q	Front Axle Centre to Machine Front	3352 mm (10 ft. 12 in.)
R	Front Axle Centre to Artic Centre	1558 mm (5 ft. 1 in.)
S	Approach Angle	22°
T	Maximum Bin Tip Angle	55°
U	Maximum Articulation Angle	42°
V	Front Tie Down Height	1263 mm (4 ft. 2 in.)
W	Machine Lifting Centres	10116 mm (33 ft. 2 in.)
X	Inner Turning Circle Radius	4247 mm (13 ft. 11 in.)
Y	Outer Turning Circle Radius	9524 mm (31 ft. 3 in.)

Grade Ability / Rimpull

1. Determine tractive force by finding intersection of vehicle mass line and grade line. NOTE: 2% typical rolling resistance is already assumed in chart and grade line.
2. From this intersection, move straight right across charts until line intersects rimpull curve.
3. Read down from this point to determine maximum speed attained at that tractive resistance.

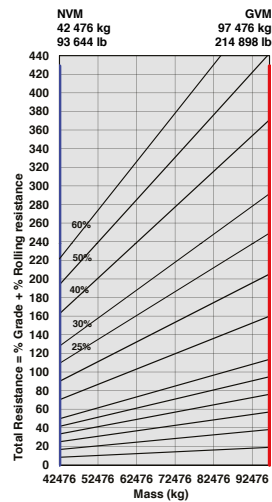

ADT, B60E 4X4 - Tractive Effort

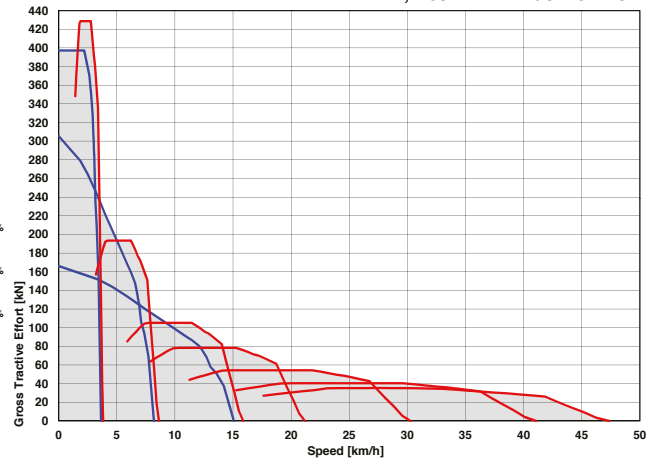

Retardation

1. Determine retardation force by finding intersection of vehicle mass line and grade line. NOTE: 2% typical rolling resistance is already assumed in chart and grade line.
2. From this intersection, move straight right across charts until line intersects the curve.
3. Read down from this point to determine maximum speed.

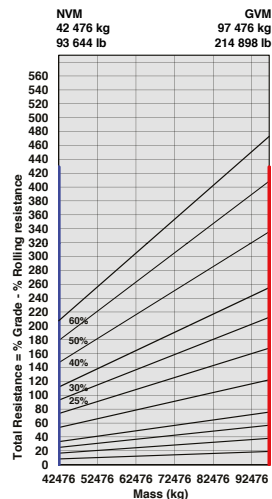

ADT, B60E 4X4 - Retardation

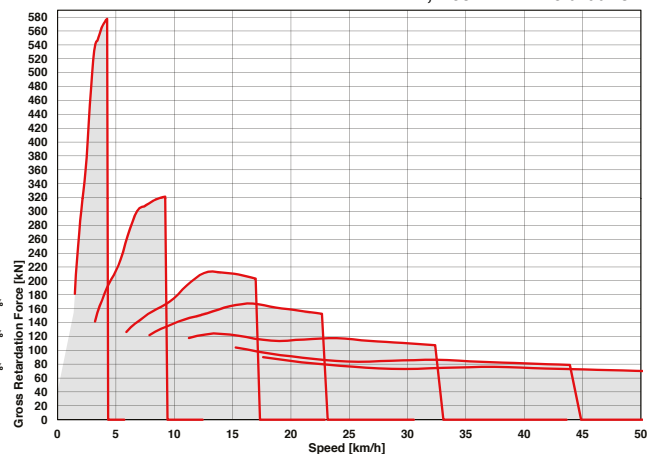

Features and Options

● STANDARD ▲ OPTION

ENGINE

- Engine valve brake
- Dual-element air cleaner with dust ejector valve
- Precleaner with automatic dust scavenging
- Water separator
- Serpentine drive belt with automatic tensioner
- Provision for fast fill
- Wet-sleeve cylinder liners

COOLING

- Crankshaft mounted electronically controlled viscous fan drive
- Fan guard

PNEUMATIC SYSTEM

- Engine-mounted compressor
- Air drier with heater
- Integral unloader valve

ELECTRICAL SYSTEM

- Battery disconnect
- LED Drive Lights
- Air Horn
- Reverse alarm
- ▲ White noise reverse alarm
- Rotating Beacon
- Pitch Roll Sensor
- LED reverse lights
- ▲ Halogen reverse lights

STEERING SYSTEM

- Bi-directional ground-driven secondary steering pump

CAB

- ROPS/FOPS certification
- Tilt cab
- Gas strut-supported door
- I-Tip programmable dump-body tip settings
- HVAC Climate control system
- AM/FM radio/CD player
- Rear window guard
- Wiper/washer with intermittent control
- Tilt and telescoping steering wheel
- Centre-mount air-suspension seat
- LED Work Lights
- ▲ Rotating beacon: seat belt installation
- ▲ Remote engine and machine isolation
- Remote battery jump start
- Retractable 3 point seat belt
- Heated seat
- Foldaway trainer seat with retractable seat belt

CAB

- 12-volt power outlet
- Cab utility bin (removable)
- Cup holder
- Cooled/heated lunch box
- Electric adjustable and heated mirrors
- Deluxe 10" colour LCD:
Speedometer / Fuel gauge /
Transmission oil temperature gauge /
Engine coolant temperature gauge /
LED function/warning indicators and audible alarm / Transmission gear selection /
Tachometer / Battery voltage / Hour meter /
Odometer / Fuel consumption / Tip counter /
Trip timer / Trip distance / Metric/English units /
Service codes/diagnostics.
- Backlit sealed switch module functions with:
Retarding aggressiveness / Transfer case differential lock / Transmission gear hold /
Dump-body tip limit / Automatic dump-body tip settings / Airconditioner / Heater controls /
Preselected Speed Control.

DUMP BODY

- Dump-body mechanical locks (x2). Partially up and fully up
- ▲ Body liner
- ▲ Body heater
- ▲ Less dump body and cylinders
- ▲ Bin pole lockout

OTHER

- Automation Traction Control (ATC)
- Wet disc brakes
- Automatic greasing
- Onboard Weighing
- Load lights: stacks
- Comfort Ride Suspension (Front)
- Reverse Camera
- Hand Rails
- Cab Peak
- ▲ High Pressure Hydraulic filter
- ▲ Fuel Heater
- Remote transmission filter
- Engine and transmission remote drain-gravity
- ▲ Engine and transmission remote drain-scavange
- ▲ Window smash button
- High visibility mirrors
- Fleetm@tic Classic Package for 2 years

The compilation of standard and optional equipment may vary by market region. Please check with your local distributor.

All dimensions are shown in millimetres, unless otherwise stated between brackets.
Under our policy of continuous improvement, we reserve the right to change technical data and design without prior notice. Photographs featured in this brochure may include optional equipment.

BELL INTERNATIONAL: Tel: +27 (0)35-907 9431

E-mail: marketing@bellequipment.com Web: www.bellequipment.com

 Tel: +61 (0)8-9356-1033
 Tel: +49 (0)6631 / 91-13-0
 Tel: +27 (0)11-928-9700
 Tel: +44 (0)1283-712862

 Tel: +33 (0)5-55-89-23-56
 Tel: +7-495-287-80-02
 Tel: +1-855-494-2355

**Strong Reliable Machines
Strong Reliable Support**

BELL